



Contents

1. Handling Precautions 5

2. General Description..... 6

 2.1 General Specification 6

 2.2 Optical Characteristics..... 7

3. Functional Block Diagram..... 12

4. Absolute Maximum Ratings 13

 4.1 Absolute Ratings of TFT LCD Module.....13

 4.2 Absolute Ratings of Environment13

5. Electrical Characteristics 14

 5.1 TFT LCD Module14

 5.2 Backlight Unit16

6. Signal Interface Characteristic 17

 6.1 Pixel Format Image17

 6.2 The Input Data Format.....18

 6.3 Integration Interface Requirement19

 6.4 Interface Timing21

7. Panel Reliability Test..... 23

 7.1 Vibration Test.....23

 7.2 Shock Test23

 7.3 Reliability Test23

8. Mechanical Characteristics 24

 8.1 LCM Outline Dimension24

 8.2 Screw Hole Depth and Center Position.....26

9. Shipping and Package 27

 9.1 Shipping Label Format27

 9.2 Carton Package.....28

 9.3 Shipping Package of Palletizing Sequence28

10. Appendix: EDID Description 29



Record of Revision

Version and Date	Page	Old description	New Description	Remark																														
0.1 2008/12/26	All	First Edition for Customer																																
0.2 2009/01/07	1	Module: 11.6"	Module: 11.6" (11.57")	modified																														
	34	EDID: TBD	EDID:Added	Added																														
0.3 2009/02/13	6	Response Time Rising: TBD(typ), TBD(max) Falling: TBD(typ), TBD(max)	Response Time Rising: 6ms(typ), 8ms(max) Falling: 2ms(typ), 4ms(max)	Updated																														
	15	LED Power Consumption and LED Life-Time <table border="1" style="width:100%; border-collapse: collapse;"> <thead> <tr> <th></th> <th>min</th> <th>typ</th> <th>max</th> <th>unit</th> </tr> </thead> <tbody> <tr> <td>LED Power consumption</td> <td></td> <td>TBD</td> <td>TBD</td> <td>Watt</td> </tr> <tr> <td>LED Life-Time</td> <td>TBD</td> <td></td> <td></td> <td></td> </tr> </tbody> </table>		min	typ	max	unit	LED Power consumption		TBD	TBD	Watt	LED Life-Time	TBD				LED Power Consumption and LED Life-Time <table border="1" style="width:100%; border-collapse: collapse;"> <thead> <tr> <th></th> <th>min</th> <th>typ</th> <th>max</th> <th>unit</th> </tr> </thead> <tbody> <tr> <td>LED Power consumption</td> <td></td> <td>2710</td> <td>2880</td> <td>mWatt</td> </tr> <tr> <td>LED Life-Time</td> <td>15000</td> <td></td> <td></td> <td></td> </tr> </tbody> </table>		min	typ	max	unit	LED Power consumption		2710	2880	mWatt	LED Life-Time	15000				Updated
	min	typ	max	unit																														
LED Power consumption		TBD	TBD	Watt																														
LED Life-Time	TBD																																	
	min	typ	max	unit																														
LED Power consumption		2710	2880	mWatt																														
LED Life-Time	15000																																	
	25	LVDS Connector Type <table border="1" style="width:100%; border-collapse: collapse;"> <thead> <tr> <th>Type / Part Number</th> <th></th> </tr> </thead> <tbody> <tr> <td></td> <td>IPEX 20455-040E-12 or compatible</td> </tr> </tbody> </table>	Type / Part Number			IPEX 20455-040E-12 or compatible	LVDS Connector Type <table border="1" style="width:100%; border-collapse: collapse;"> <thead> <tr> <th>Type / Part Number</th> <th></th> </tr> </thead> <tbody> <tr> <td></td> <td>IPEX 20455-040E-12A or compatible</td> </tr> </tbody> </table>	Type / Part Number			IPEX 20455-040E-12A or compatible	Modified																						
Type / Part Number																																		
	IPEX 20455-040E-12 or compatible																																	
Type / Part Number																																		
	IPEX 20455-040E-12A or compatible																																	
	31	Screw Hole Depth and Center Position TBD	Screw Hole Depth and Center Position Attached	Updated																														
	32	Shipping Label Format: TBD	Shipping Label Format:Added	Updated																														
	33	Carton package:TBD	Carton package: Added	Updated																														
	34	Shipping package of palletizing sequence:TBD	Shipping package of palletizing sequence:Added	Updated																														
	19	6.3 Integration Interface and Pin Assignment <table border="1" style="width:100%; border-collapse: collapse;"> <thead> <tr> <th></th> <th>VLED</th> <th>LED Power Supply</th> </tr> </thead> <tbody> <tr> <td>38</td> <td>VLED</td> <td>LED Power Supply 7V-20V</td> </tr> <tr> <td>39</td> <td>VLED</td> <td>LED Power Supply 7V-20V</td> </tr> <tr> <td>40</td> <td>VLED</td> <td>LED Power Supply 7V-20V</td> </tr> </tbody> </table>		VLED	LED Power Supply	38	VLED	LED Power Supply 7V-20V	39	VLED	LED Power Supply 7V-20V	40	VLED	LED Power Supply 7V-20V	6.3 Integration Interface and Pin Assignment <table border="1" style="width:100%; border-collapse: collapse;"> <thead> <tr> <th></th> <th>VLED</th> <th>LED Power Supply</th> </tr> </thead> <tbody> <tr> <td>38</td> <td>VLED</td> <td>LED Power Supply 6V-21V</td> </tr> <tr> <td>39</td> <td>VLED</td> <td>LED Power Supply 6V-21V</td> </tr> <tr> <td>40</td> <td>VLED</td> <td>LED Power Supply 6V-21V</td> </tr> </tbody> </table>		VLED	LED Power Supply	38	VLED	LED Power Supply 6V-21V	39	VLED	LED Power Supply 6V-21V	40	VLED	LED Power Supply 6V-21V	Modified						
	VLED	LED Power Supply																																
38	VLED	LED Power Supply 7V-20V																																
39	VLED	LED Power Supply 7V-20V																																
40	VLED	LED Power Supply 7V-20V																																
	VLED	LED Power Supply																																
38	VLED	LED Power Supply 6V-21V																																
39	VLED	LED Power Supply 6V-21V																																
40	VLED	LED Power Supply 6V-21V																																
	6	Color / Chromaticity Coordinates:TBD	Color / Chromaticity Coordinates:Updated	Update																														
		LED Power Consumption and LED Life-Time <table border="1" style="width:100%; border-collapse: collapse;"> <thead> <tr> <th></th> <th>min</th> <th>typ</th> <th>max</th> <th>unit</th> </tr> </thead> <tbody> <tr> <td>LED Power consumption</td> <td></td> <td>2710</td> <td>2880</td> <td>mWatt</td> </tr> </tbody> </table>		min	typ	max	unit	LED Power consumption		2710	2880	mWatt	LED Power Consumption and LED Life-Time <table border="1" style="width:100%; border-collapse: collapse;"> <thead> <tr> <th></th> <th>min</th> <th>typ</th> <th>max</th> <th>unit</th> </tr> </thead> <tbody> <tr> <td>LED Power consumption</td> <td></td> <td>2.71</td> <td>2.76</td> <td>Watt</td> </tr> </tbody> </table>		min	typ	max	unit	LED Power consumption		2.71	2.76	Watt	Updated										
	min	typ	max	unit																														
LED Power consumption		2710	2880	mWatt																														
	min	typ	max	unit																														
LED Power consumption		2.71	2.76	Watt																														
	22	Timing Characteristics: TBD	Timing Characteristics:Updated	Update																														
0.5 2009/04/16	15	5.2 Backlight Unit	5.2 Backlight Unit 5.2.1 LED characteristics 5.2.2 Backlight input signal characteristics	Modified																														
	19	Pin Assignment	Pin Assignment: pin35, 38, 39, 40 description is modified	Modified																														
	20	6.5 Power ON/OFF Sequence	6.5 Power ON/OFF Sequence: Timing	Modified																														



Product Specification

AU OPTRONICS CORPORATION

			Definition modified																					
0.6 2009/06/24	16	PWM Input Frequency	PWM Input Frequency	Modified																				
		<table border="1"> <thead> <tr> <th>Symbol[Ⓟ]</th> <th>Min[Ⓟ]</th> <th>Typ[Ⓟ]</th> <th>Max[Ⓟ]</th> <th>Units[Ⓟ]</th> </tr> </thead> <tbody> <tr> <td>FPWM[Ⓟ]</td> <td>100[Ⓟ]</td> <td>-[Ⓟ]</td> <td>10K[Ⓟ]</td> <td>Hz[Ⓟ]</td> </tr> </tbody> </table>	Symbol [Ⓟ]	Min [Ⓟ]	Typ [Ⓟ]	Max [Ⓟ]	Units [Ⓟ]	FPWM [Ⓟ]	100 [Ⓟ]	- [Ⓟ]	10K [Ⓟ]	Hz [Ⓟ]	<table border="1"> <thead> <tr> <th>Symbol[Ⓟ]</th> <th>Min[Ⓟ]</th> <th>Typ[Ⓟ]</th> <th>Max[Ⓟ]</th> <th>Units[Ⓟ]</th> </tr> </thead> <tbody> <tr> <td>FPWM[Ⓟ]</td> <td>990[Ⓟ]</td> <td>1K[Ⓟ]</td> <td>10K[Ⓟ]</td> <td>Hz[Ⓟ]</td> </tr> </tbody> </table>	Symbol [Ⓟ]	Min [Ⓟ]	Typ [Ⓟ]	Max [Ⓟ]	Units [Ⓟ]	FPWM [Ⓟ]	990 [Ⓟ]	1K [Ⓟ]	10K [Ⓟ]	Hz [Ⓟ]	
Symbol [Ⓟ]	Min [Ⓟ]	Typ [Ⓟ]	Max [Ⓟ]	Units [Ⓟ]																				
FPWM [Ⓟ]	100 [Ⓟ]	- [Ⓟ]	10K [Ⓟ]	Hz [Ⓟ]																				
Symbol [Ⓟ]	Min [Ⓟ]	Typ [Ⓟ]	Max [Ⓟ]	Units [Ⓟ]																				
FPWM [Ⓟ]	990 [Ⓟ]	1K [Ⓟ]	10K [Ⓟ]	Hz [Ⓟ]																				
0.7 2009/07/10	6	Surface Treatment: Reflection <4%	Surface Treatment: Reflection 4.3%	Update																				
	7		Response time	add																				
			<table border="1"> <thead> <tr> <th>Conditions</th> <th>Min.</th> <th>Typ.</th> <th>Max.</th> </tr> </thead> <tbody> <tr> <td>Rising</td> <td>-</td> <td>3</td> <td>-</td> </tr> <tr> <td>Falling</td> <td>-</td> <td>5</td> <td>-</td> </tr> </tbody> </table>	Conditions	Min.	Typ.	Max.	Rising	-	3	-	Falling	-	5	-									
Conditions	Min.	Typ.	Max.																					
Rising	-	3	-																					
Falling	-	5	-																					
	15	5.1.2 Signal Electrical Characteristics LVDS Signal Waveform figure	5.1.2 Signal Electrical Characteristics LVDS Signal Waveform figure	Modified																				
	19	LVDS Connector Type	LVDS Connector Type	Update																				
		<table border="1"> <thead> <tr> <th>Type / Part Number</th> <th>IPEX 20455-040E-12A or compatible</th> </tr> </thead> <tbody> <tr> <td></td> <td></td> </tr> </tbody> </table>	Type / Part Number	IPEX 20455-040E-12A or compatible			<table border="1"> <thead> <tr> <th>Type / Part Number</th> <th>IPEX 20455-040E-12R or compatible</th> </tr> </thead> <tbody> <tr> <td></td> <td></td> </tr> </tbody> </table>	Type / Part Number	IPEX 20455-040E-12R or compatible															
Type / Part Number	IPEX 20455-040E-12A or compatible																							
Type / Part Number	IPEX 20455-040E-12R or compatible																							

1. Handling Precautions

- 1) Since front polarizer is easily damaged, pay attention not to scratch it.
- 2) Be sure to turn off power supply when inserting or disconnecting from input connector.
- 3) Wipe off water drop immediately. Long contact with water may cause discoloration or spots.
- 4) When the panel surface is soiled, wipe it with absorbent cotton or other soft cloth.
- 5) Since the panel is made of glass, it may break or crack if dropped or bumped on hard surface.
- 6) Since CMOS LSI is used in this module, take care of static electricity and insure human earth when handling.
- 7) Do not open nor modify the Module Assembly.
- 8) Do not press the reflector sheet at the back of the module to any directions.
- 9) At the insertion or removal of the Signal Interface Connector, be sure not to rotate nor tilt the Interface Connector of the TFT Module.
- 11) After installation of the TFT Module into an enclosure (Notebook PC Bezel, for example), do not twist nor bend the TFT Module even momentarily. At designing the enclosure, it should be taken into consideration that no bending/twisting forces are applied to the TFT Module from outside. Otherwise the TFT Module may be damaged.
- 12) Small amount of materials having no flammability grade is used in the LCD module. The LCD module should be supplied by power complied with requirements of Limited Power Source (IEC60950 or UL1950), or be applied exemption.
- 13) Disconnecting power supply before handling LCD modules, it can prevent electric shock, DO NOT TOUCH the electrode parts, cables, connectors and LED circuit part of TFT module that a LED light bar build in as a light source of back light unit. It can prevent electrostatic breakdown.



2. General Description

B116XW02 V0 is a Color Active Matrix Liquid Crystal Display composed of a TFT LCD panel, a driver circuit, and LED backlight system. The screen format is intended to support the 16:9 HD, 1366(H) x768(V) screen and 262k colors (RGB 6-bits data driver) with LED backlight driving circuit. All input signals are LVDS interface compatible.

B116XW02 V0 is designed for a display unit of notebook style personal computer and industrial machine.

2.1 General Specification

The following items are characteristics summary on the table at 25 °C condition:

Items	Unit	Specifications			
Screen Diagonal	[mm]	293.83			
Active Area	[mm]	256.125 X 144.0			
Pixels H x V		1366x3(RGB) x 768			
Pixel Pitch	[mm]	0.1875 x 0.1875			
Pixel Format		R.G.B. Vertical Stripe			
Display Mode		Normally White			
White Luminance (ILED=20mA) (Note: ILED is LED current)	[cd/m ²]	200 typ. (5 points average) 170 min. (5 points average)			
Luminance Uniformity		1.25 max. (5 points)			
Contrast Ratio		500:1 typ			
Response Time	[ms]	8 typ / 16 Max			
Nominal Input Voltage VDD	[Volt]	+3.3 typ.			
Power Consumption	[Watt]	4.0 max. (Include Logic and Blu power)			
Weight	[Grams]	255g max.			
Physical Size Include bracket	[mm]		Min.	Typ.	Max.
		Length	267.5	268.0	268.5
		Width	161.0	161.5	162.0
		Thickness	-	-	5.2
Electrical Interface		1 channel LVDS			
Glass Thickness	[mm]	0.5			
Surface Treatment		Glare, Hardness 3H, Reflection 4.3 %			
Support Color		262K colors (RGB 6-bit)			



Product Specification

AU OPTRONICS CORPORATION

Temperature Range Operating	[°C]	0 to +50
Storage (Non-Operating)	[°C]	-20 to +60
RoHS Compliance		RoHS Compliance

2.2 Optical Characteristics

The optical characteristics are measured under stable conditions at 25°C (Room Temperature) :

Item	Symbol	Conditions	Min.	Typ.	Max.	Unit	Note
White Luminance $I_{LED=20mA}$		5 points average	170	200	-	cd/m ²	1, 4, 5.
Viewing Angle	θ_R	Horizontal (Right) CR = 10 (Left)	40	45	-	degree	4, 9
	θ_L		40	45	-		
	ϕ_H	Vertical (Upper) CR = 10 (Lower)	10	15	-		
	ϕ_L		30	35	-		
Luminance Uniformity	δ_{5P}	5 Points	-	-	1.25		1, 3, 4
Luminance Uniformity	δ_{13P}	13 Points	-	-	1.60		2, 3, 4
Contrast Ratio	CR		400	500	-		4, 6
Cross talk	%				4		4, 7
Response Time	T_r	Rising	-	3	-	msec	4, 8
	T_f	Falling	-	5	-		
	T_{RT}	Rising + Falling	-	8	16		
Color / Chromaticity Coordinates	Red	Rx	CIE 1931	0.550	0.580	0.610	4
		Ry		0.315	0.345	0.375	
	Green	Gx		0.295	0.325	0.355	
		Gy		0.520	0.550	0.580	
	Blue	Bx		0.125	0.155	0.185	
		By		0.110	0.140	0.170	
	White	Wx		0.283	0.313	0.343	
		Wy		0.299	0.329	0.359	
NTSC	%		-	45	-		

Note 1: 5 points position (Ref: Active area)

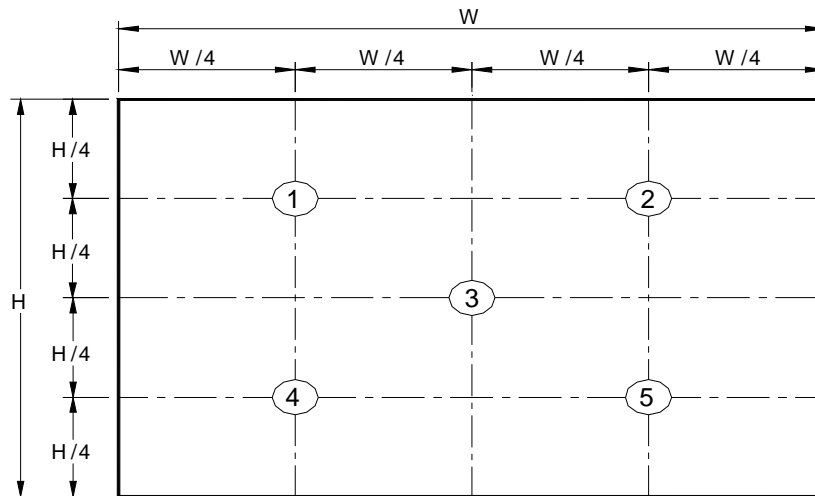

Note 2: 13 points position (Ref: Active area)

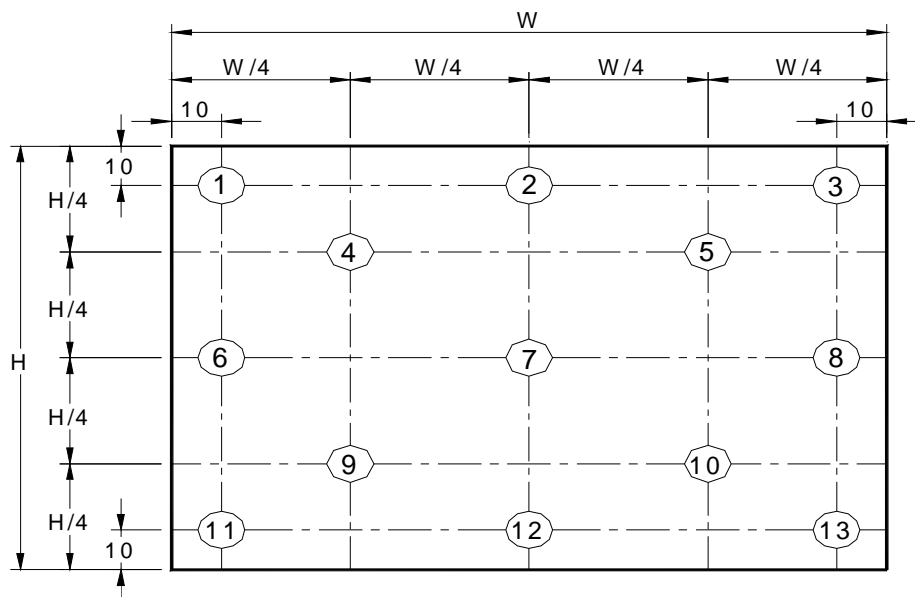

Note 3: The luminance uniformity of 5 or 13 points is defined by dividing the maximum luminance values by the minimum test point luminance

$$\delta_{w5} = \frac{\text{Maximum Brightness of five points}}{\text{Minimum Brightness of five points}}$$

$$\delta_{w13} = \frac{\text{Maximum Brightness of thirteen points}}{\text{Minimum Brightness of thirteen points}}$$

Note 4: Measurement method

The LCD module should be stabilized at given temperature for 30 minutes to avoid abrupt temperature change during measuring. In order to stabilize the luminance, the measurement should be executed after

lighting Backlight for 30 minutes in a stable, windless and dark room, and it should be measured in the center of screen.

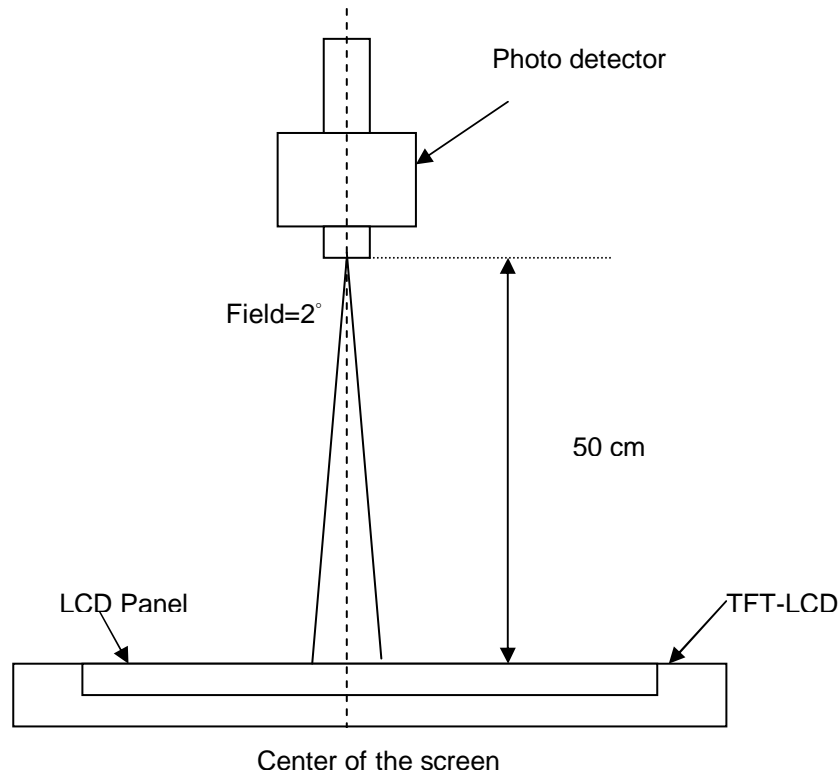

Note 5 : Definition of Average Luminance of White (Y_L):

Measure the luminance of gray level 63 at 5 points · $Y_L = [L(1) + L(2) + L(3) + L(4) + L(5)] / 5$
 $L(x)$ is corresponding to the luminance of the point X at Figure in Note (1).

Note 6 : Definition of contrast ratio:

Contrast ratio is calculated with the following formula.

$$\text{Contrast ratio (CR)} = \frac{\text{Brightness on the "White" state}}{\text{Brightness on the "Black" state}}$$

Note 7 : Definition of Cross Talk (CT)

$$CT = |Y_B - Y_A| / Y_A \times 100 (\%)$$

Where

Y_A = Luminance of measured location without gray level 0 pattern (cd/m^2)

Y_B = Luminance of measured location with gray level 0 pattern (cd/m^2)

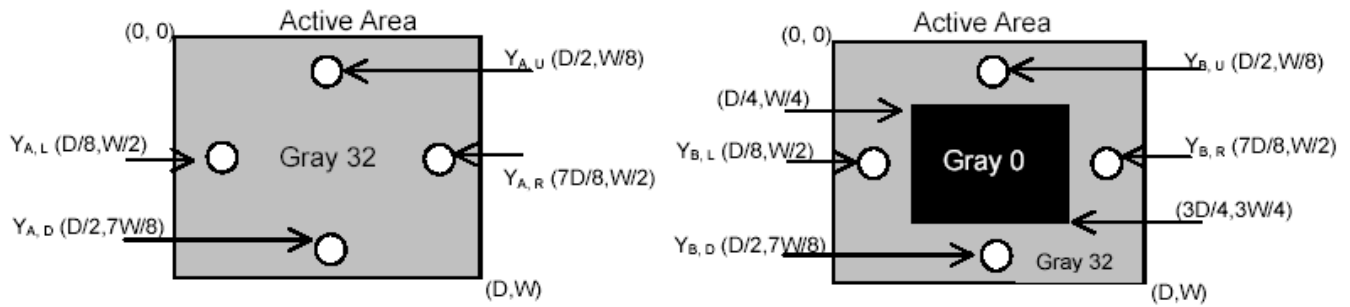

Note 8: Definition of response time:

The output signals of BM-7 or equivalent are measured when the input signals are changed from "Black" to "White" (falling time) and from "White" to "Black" (rising time), respectively. The response time interval between the 10% and 90% of amplitudes. Refer to figure as below.

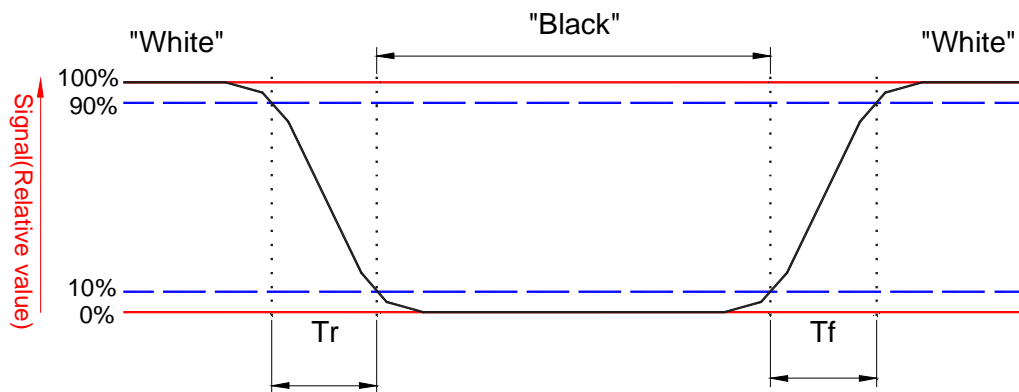

Note 9. Definition of viewing angle

Viewing angle is the measurement of contrast ratio ≥ 10 , at the screen center, over a 180° horizontal and 180° vertical range (off-normal viewing angles). The 180° viewing angle range is broken down as follows; 90° (θ) horizontal left and right and 90° (ϕ) vertical, high (up) and low (down). The measurement direction is typically perpendicular to the display surface with the screen rotated about its center to develop the desired measurement viewing angle.

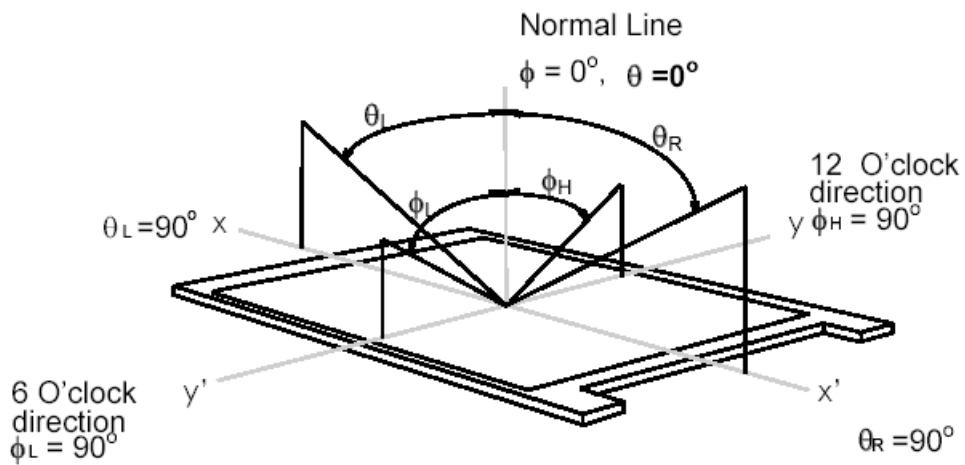

3. Functional Block Diagram

The following diagram shows the functional block of the 11.6 inches wide Color TFT/LCD 40 Pin one channel Module

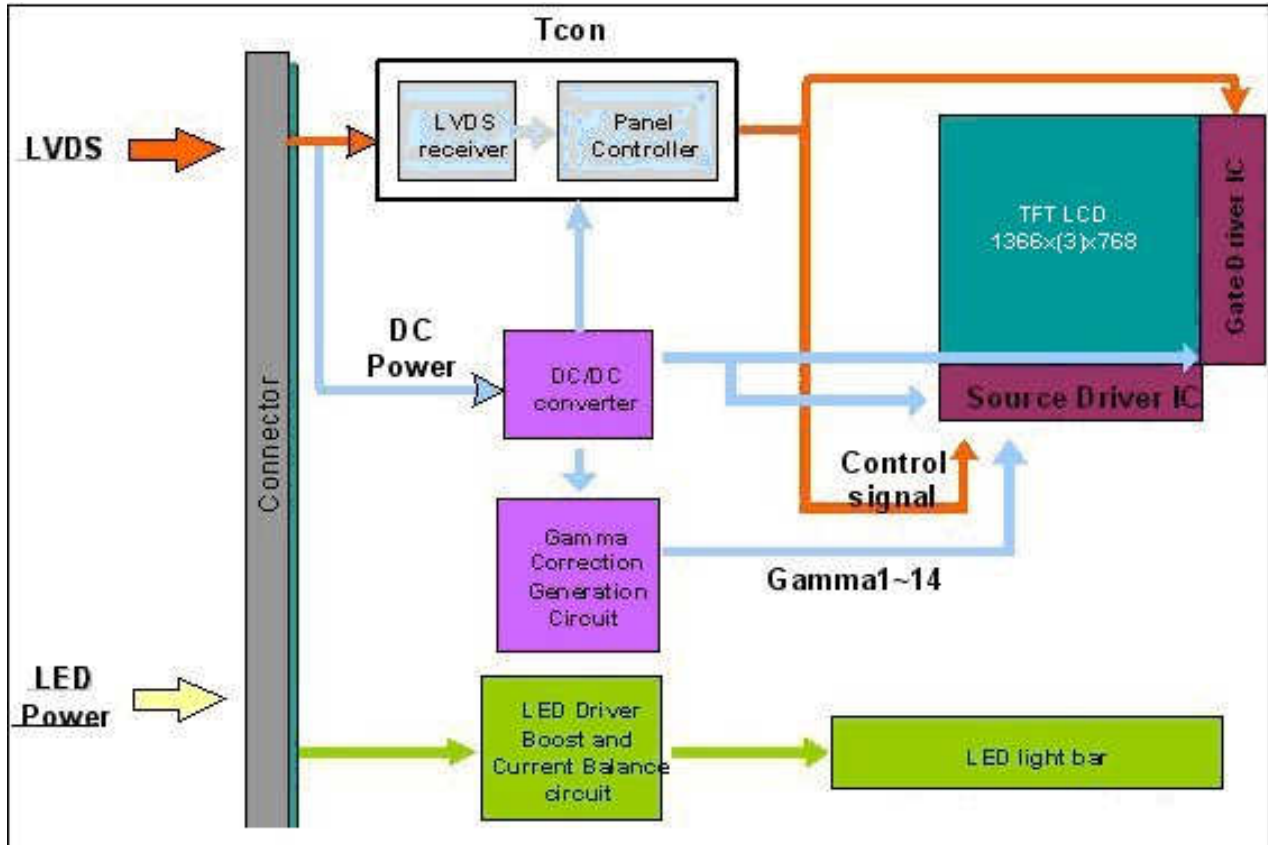

4. Absolute Maximum Ratings

An absolute maximum rating of the module is as following:

4.1 Absolute Ratings of TFT LCD Module

Item	Symbol	Min	Max	Unit	Conditions
Logic/LCD Drive	Vin	-0.3	+4.0	[Volt]	Note 1,2

4.2 Absolute Ratings of Environment

Item	Symbol	Min	Max	Unit	Conditions
Operating Temperature	TOP	0	+50	[°C]	Note 4
Operation Humidity	HOP	5	95	[%RH]	Note 4
Storage Temperature	TST	-20	+60	[°C]	Note 4
Storage Humidity	HST	5	95	[%RH]	Note 4

Note 1: At Ta (25°C)

Note 2: Permanent damage to the device may occur if exceed maximum values

Note 3: LED specification refer to section 5.2

Note 4: For quality performance, please refer to AUO IIS (Incoming Inspection Standard).

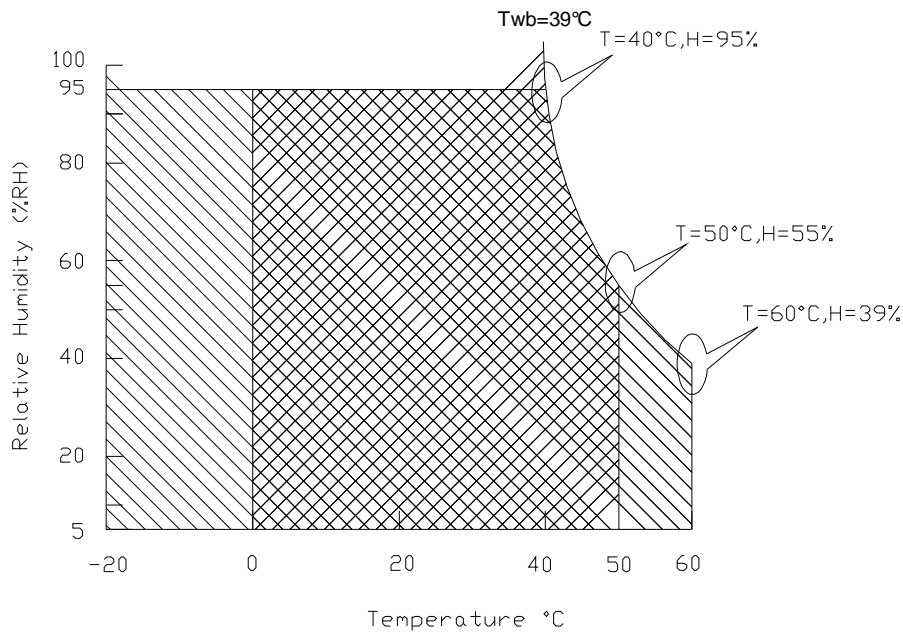

Operating Range 

Storage Range

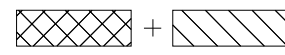

5. Electrical Characteristics

5.1 TFT LCD Module

5.1.1 Power Specification

Input power specifications are as follows;

The power specification are measured under 25°C and frame frequency under 60Hz

Symble	Parameter	Min	Typ	Max	Units	Note
VDD	Logic/LCD Drive Voltage	3.0	3.3	3.6	[Volt]	
PDD	VDD Power	-	-	0.8	[Watt]	Note 1
IDD	IDD Current	-	-	450	[mA]	Note 1
IRush	Inrush Current	-	-	2000	[mA]	Note 2
VDDrp	Allowable Logic/LCD Drive Ripple Voltage	-	-	100	[mV] p-p	

Note 1 : Maximum Measurement Condition : Black Pattern at 3.3V driving voltage. ($P_{max}=V_{3.3} \times I_{black}$)

Note 2 : Measure Condition

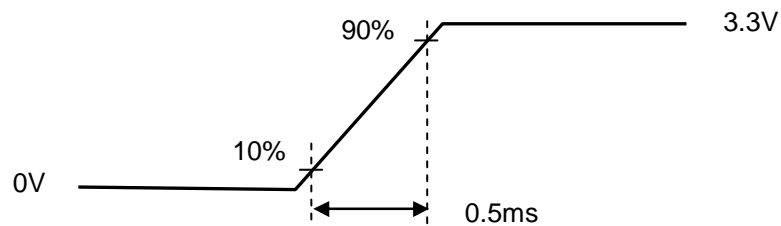
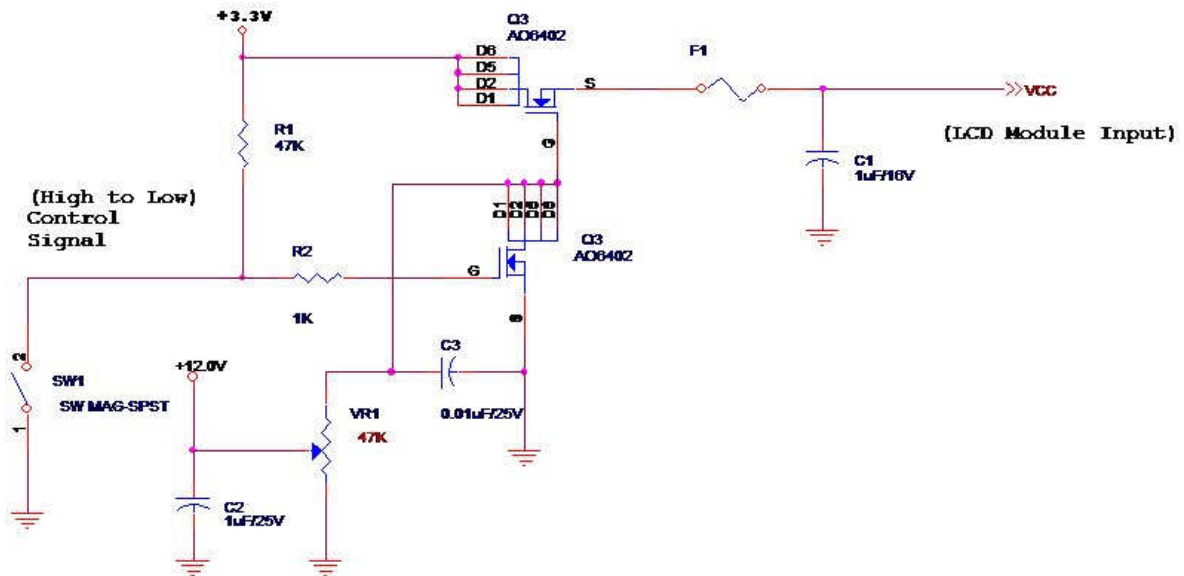

Vin rising time

5.1.2 Signal Electrical Characteristics

Input signals shall be low or High-impedance state when VDD is off.

Signal electrical characteristics are as follows;

Parameter	Condition	Min	Max	Unit
V_{th}	Differential Input High Threshold ($V_{cm}=+1.2V$)		100	[mV]
V_{tl}	Differential Input Low Threshold ($V_{cm}=+1.2V$)	-100	-	[mV]
V_{ID}	Differential Input Voltage	100	600	[mV]
V_{cm}	Differential Input Common Mode Voltage	1.125	1.375	[V]

Note: LVDS Signal Waveform

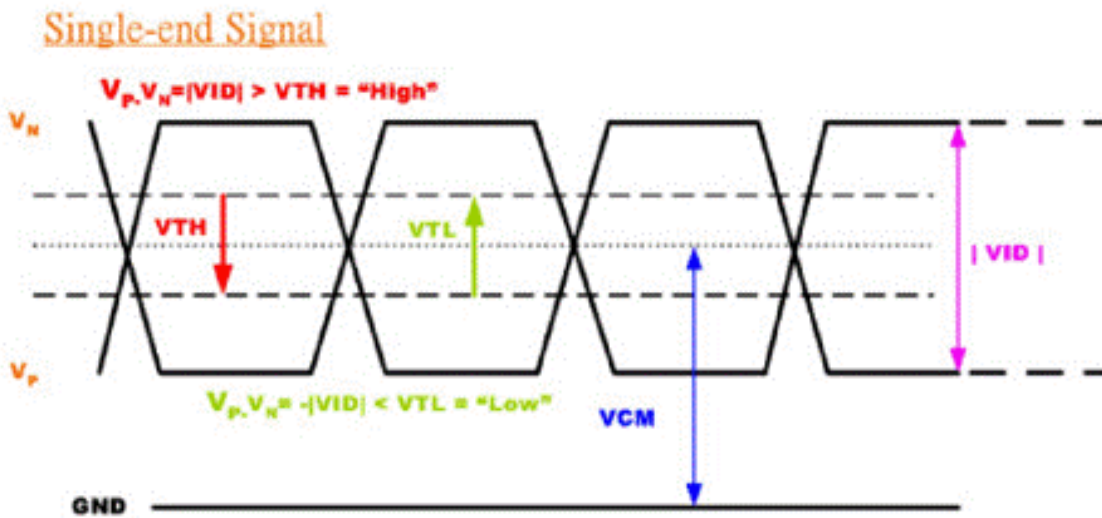



Product Specification

AU OPTRONICS CORPORATION

5.2 Backlight Unit

5.2.1 LED characteristics

Parameter	Symbol	Min	Typ	Max	Units	Condition
Backlight Power Consumption	PLED	-	-	2.76	[Watt]	(Ta=25°C), Note 1 Vin =12V
LED Life-Time	N/A	10,000	-	-	Hour	(Ta=25°C), Note 2 If=20 mA

Note 1: Calculator value for reference $P_{LED} = V_F$ (Normal Distribution) * I_F (Normal Distribution) / Efficiency

Note 2: The LED life-time define as the estimated time to 50% degradation of initial luminous.

5.2.2 Backlight input signal characteristics

Parameter	Symbol	Min	Typ	Max	Units	Remark
LED Power Supply	VLED	6.0	12.0	21.0	[Volt]	Define as Connector Interface (Ta=25°C)
LED Enable Input High Level	VLED_EN	2.5	-	5.5	[Volt]	
LED Enable Input Low Level		-	-	0.8	[Volt]	
PWM Logic Input High Level	VPWM_EN	2.5	-	5.5	[Volt]	
PWM Logic Input Low Level		-	-	0.8	[Volt]	
PWM Input Frequency	FPWM	990	1K	10K	Hz	
PWM Duty Ratio	Duty	5	--	100	%	

6.2 The Input Data Format

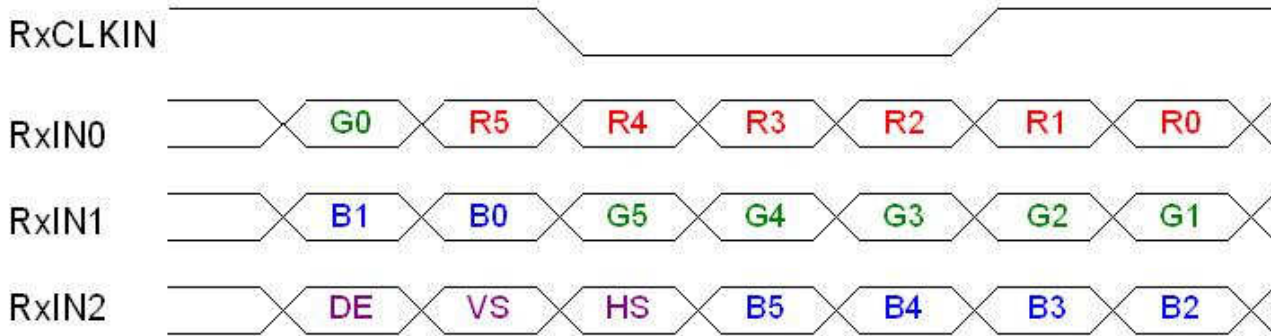

Signal Name	Description	
R5 R4 R3 R2 R1 R0	Red Data 5 (MSB) Red Data 4 Red Data 3 Red Data 2 Red Data 1 Red Data 0 (LSB)	Red-pixel Data Each red pixel's brightness data consists of these 6 bits pixel data.
G5 G4 G3 G2 G1 G0	Green Data 5 (MSB) Green Data 4 Green Data 3 Green Data 2 Green Data 1 Green Data 0 (LSB)	Green-pixel Data Each green pixel's brightness data consists of these 6 bits pixel data.
B5 B4 B3 B2 B1 B0	Blue Data 5 (MSB) Blue Data 4 Blue Data 3 Blue Data 2 Blue Data 1 Blue Data 0 (LSB)	Blue-pixel Data Each blue pixel's brightness data consists of these 6 bits pixel data.
RxCLKIN	Data Clock	The signal is used to strobe the pixel data and DE signals. All pixel data shall be valid at the falling edge when the DE signal is high.
DE	Display Timing	This signal is strobed at the falling edge of RxCLKIN. When the signal is high, the pixel data shall be valid to be displayed.
VS	Vertical Sync	The signal is synchronized to RxCLKIN .
HS	Horizontal Sync	The signal is synchronized to RxCLKIN .

Note: Output signals from any system shall be low or High-impedance state when VDD is off.

6.3 Integration Interface Requirement

6.3.1 Connector Description

Physical interface is described as for the connector on module.

These connectors are capable of accommodating the following signals and will be following components.

Connector Name / Designation	For Signal Connector
Manufacturer	IPEX or compatible
Type / Part Number	IPEX 20347-340E-12R or compatible
Mating Housing/Part Number	IPEX 20345-340E-12 or compatible

6.3.2 Pin Assignment

LVDS is a differential signal technology for LCD interface and high speed data transfer device.

PIN#	Signal Name	Description
1	NC	No Connection (Reserve)
2	VDD	Power Supply +3.3V
3	VDD	Power Supply +3.3V
4	VEDID	EDID +3.3V Power
5	NC	No Connect (Reserve)
6	CLK_EDID	EDID Clock Input
7	DAT_EDID	EDID Data Input
8	RxOIN0-	-LVDS Differential Data INPUT(Odd R0-R5,G0)
9	RxOIN0+	+LVDS Differential Data INPUT(Odd R0-R5,G0)
10	VSS	Ground
11	RxOIN1-	-LVDS Differential Data INPUT(Odd G1-G5,B0-B1)
12	RxOIN1+	+LVDS Differential Data INPUT(Odd G1-G5,B0-B1)
13	VSS	Ground
14	RxOIN2-	-LVDS Differential Data INPUT(Odd B2-B5,HS,VS,DE)
15	RxOIN2+	+LVDS Differential Data INPUT(Odd B2-B5,HS,VS,DE)
16	VSS	Ground
17	RxOCKIN-	-LVDS Odd Differential Clock INPUT
18	RxOCKIN+	-LVDS Odd Differential Clock INPUT
19	VSS	Ground
20	NC	No connection
21	NC	No connection
22	NC	No connection

23	NC	No connection
24	NC	No connection
25	NC	No connection
26	NC	No connection
27	NC	No connection
28	NC	No connection
29	NC	No connection
30	NC	No connection
31	VLED_GND	LED Ground
32	VLED_GND	LED Ground
33	VLED_GND	LED Ground
34	NC	No Connection (Reserve)
35	VPWM_EN	PWM logic input level
36	VLED_EN	LED enable input level
37	NC	No Connection (Reserve)
38	VLED	LED Power Supply
39	VLED	LED Power Supply
40	VLED	LED Power Supply

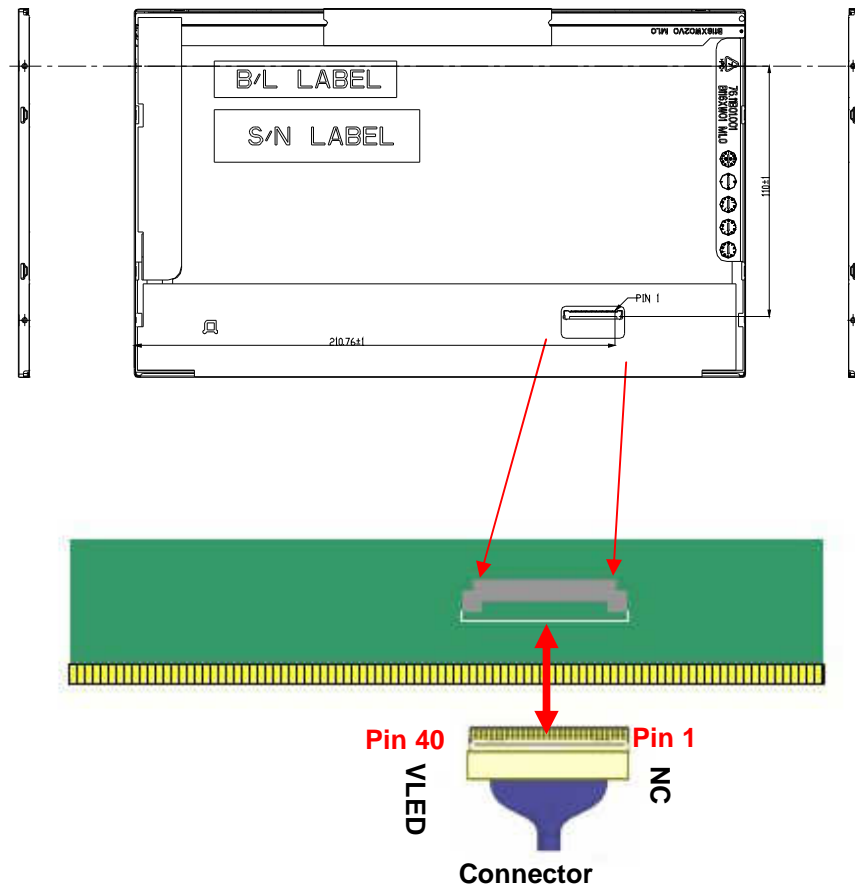

Note1: Input signals shall be low or High-impedance state when VDD is off.

6.4 Interface Timing

6.4.1 Timing Characteristics

Basically, interface timings should match the 1366x768 /60Hz manufacturing guide line timing.

Parameter	Symbol	Min.	Typ.	Max.	Unit	
Frame Rate	-	50	60	-	Hz	
Clock frequency	$1/T_{Clock}$	50	72	-	MHz	
Vertical Section	Period	T_V	803	-	1023	T_{Line}
	Active	T_{VD}	768			
	Blanking	T_{VB}	35	-	255	
Horizontal Section	Period	T_H	1494	-	2047	T_{Clock}
	Active	T_{HD}	1366			
	Blanking	T_{HB}	128	-	681	

Note : DE mode only

6.4.2 Timing diagram

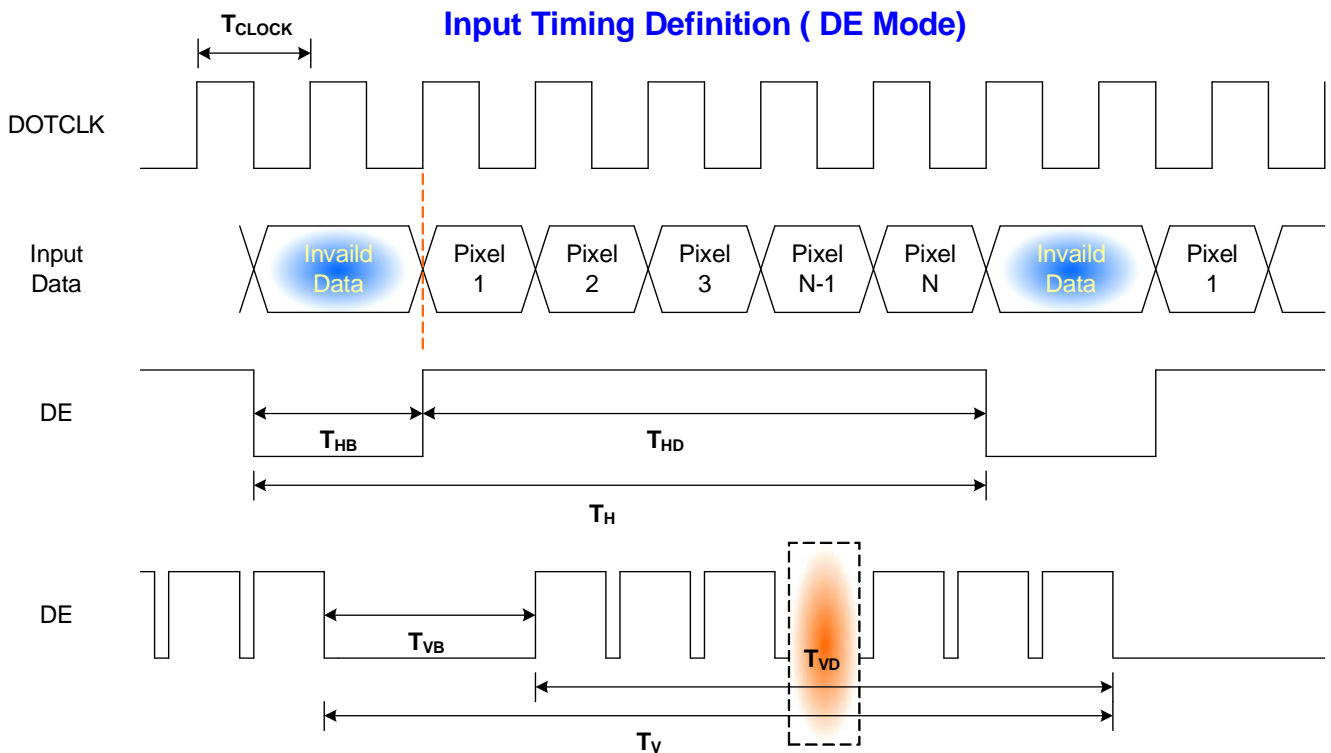

6.5 Power ON/OFF Sequence

Power on/off sequence is as follows. Interface signals and LED on/off sequence are also shown in the chart. Signals from any system shall be Hi-Z state or low level when VDD is off

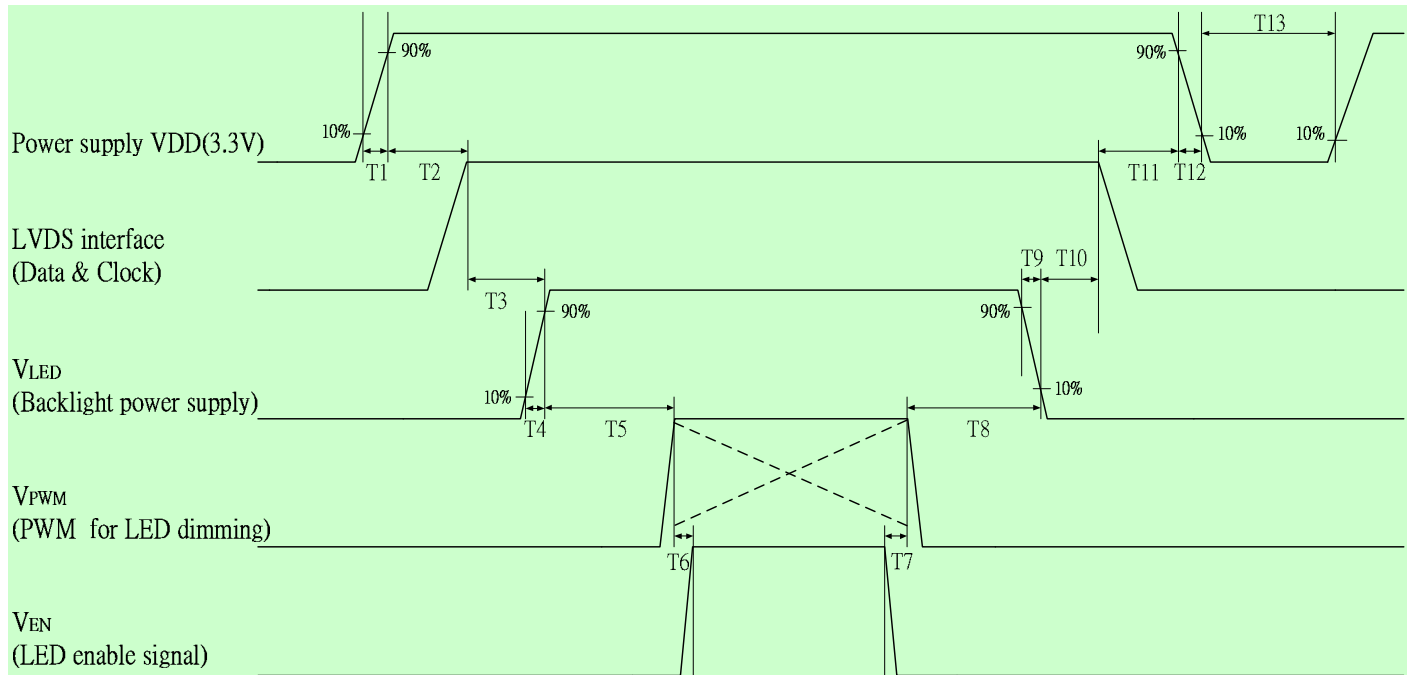

Power Sequence Timing				
Parameter	Value			Units
	Min.	Typ.	Max.	
T1	0.5	-	10	ms
T2	0	-	50	
T3	200	-	-	
T4	0.5	-	10	
T5	10	-	-	
T6	10	-	-	
T7	0	-	-	
T8	10	-	-	
T9	0	-	10	
T10	200	-	-	
T11	0.5	-	50	
T12	0	-	10	
T13	400	-	-	

Note: If T3, T5, T6 couldn't match above specifications, must request $T3+T5+T6 > 200\text{ms}$ at least

7. Panel Reliability Test

7.1 Vibration Test

Test Spec:

- Test method: Non-Operation
- Acceleration: 1.5 G
- Frequency: 10 - 500Hz Random
- Sweep: 30 Minutes each Axis (X, Y, Z)

7.2 Shock Test

Test Spec:

- Test method: Non-Operation
- Acceleration: 220 G , Half sine wave
- Active time: 2 ms
- Pulse: X,Y,Z .one time for each side

7.3 Reliability Test

Items	Required Condition	Note
Temperature Humidity Bias	Ta= 40°C, 90%RH, 300h	
High Temperature Operation	Ta= 50°C, Dry, 300h	
Low Temperature Operation	Ta= 0°C, 300h	
High Temperature Storage	Ta= 60°C, 35%RH, 300h	
Low Temperature Storage	Ta= -20°C, 50%RH, 250h	
Thermal Shock Test	Ta=-20°C to 60°C, Duration at 30 min, 100 cycles	
ESD	Contact : ±8 KV Air : ±15 KV	Note 1

Note1: According to EN 61000-4-2 , ESD class B: Some performance degradation allowed. No data lost
 . Self-recoverable. No hardware failures.

Remark: MTBF (Excluding the LED): 30,000 hours with a confidence level 90%



Product Specification

AU OPTRONICS CORPORATION

8. Mechanical Characteristics

8.1 LCM Outline Dimension

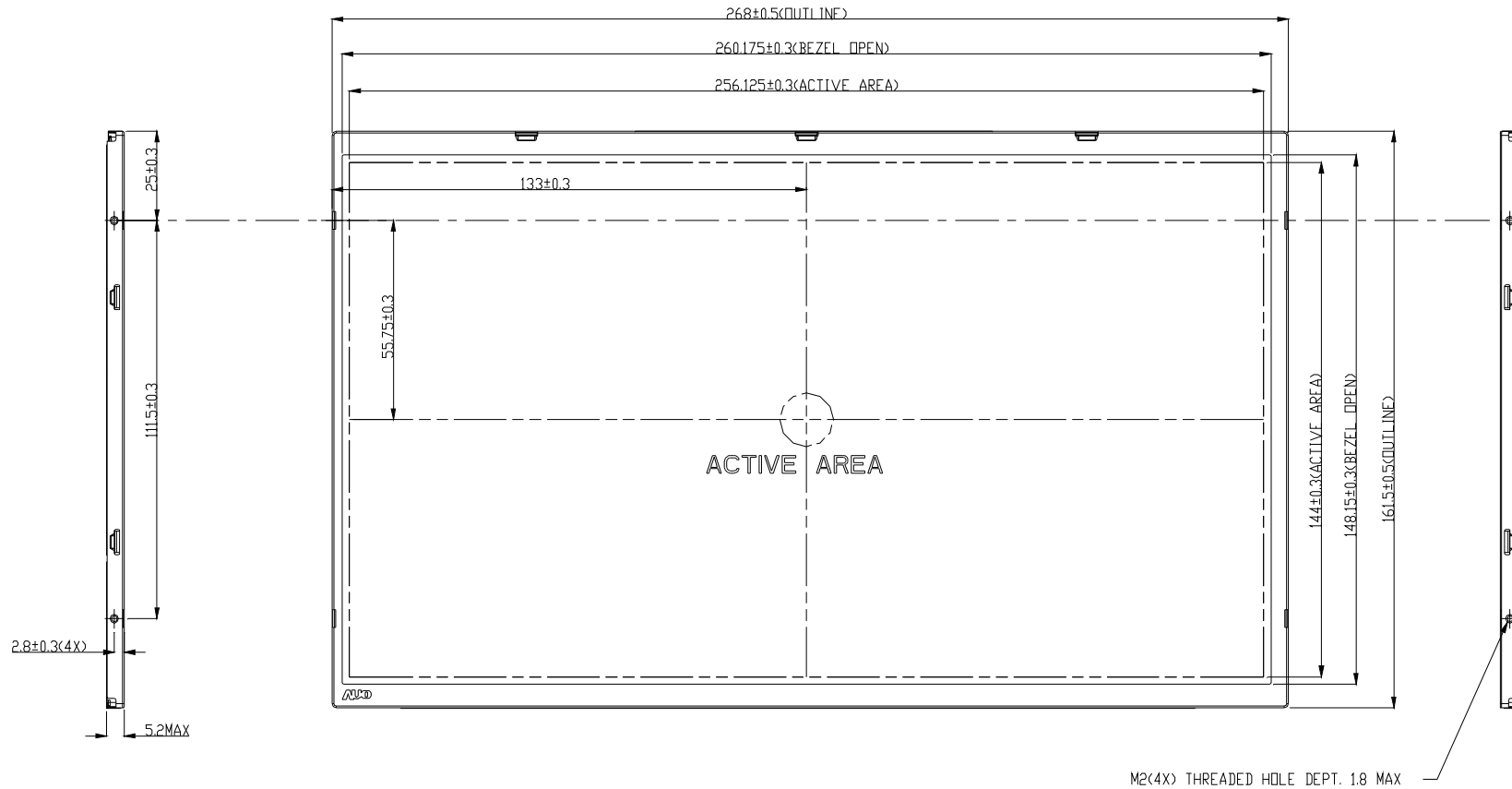

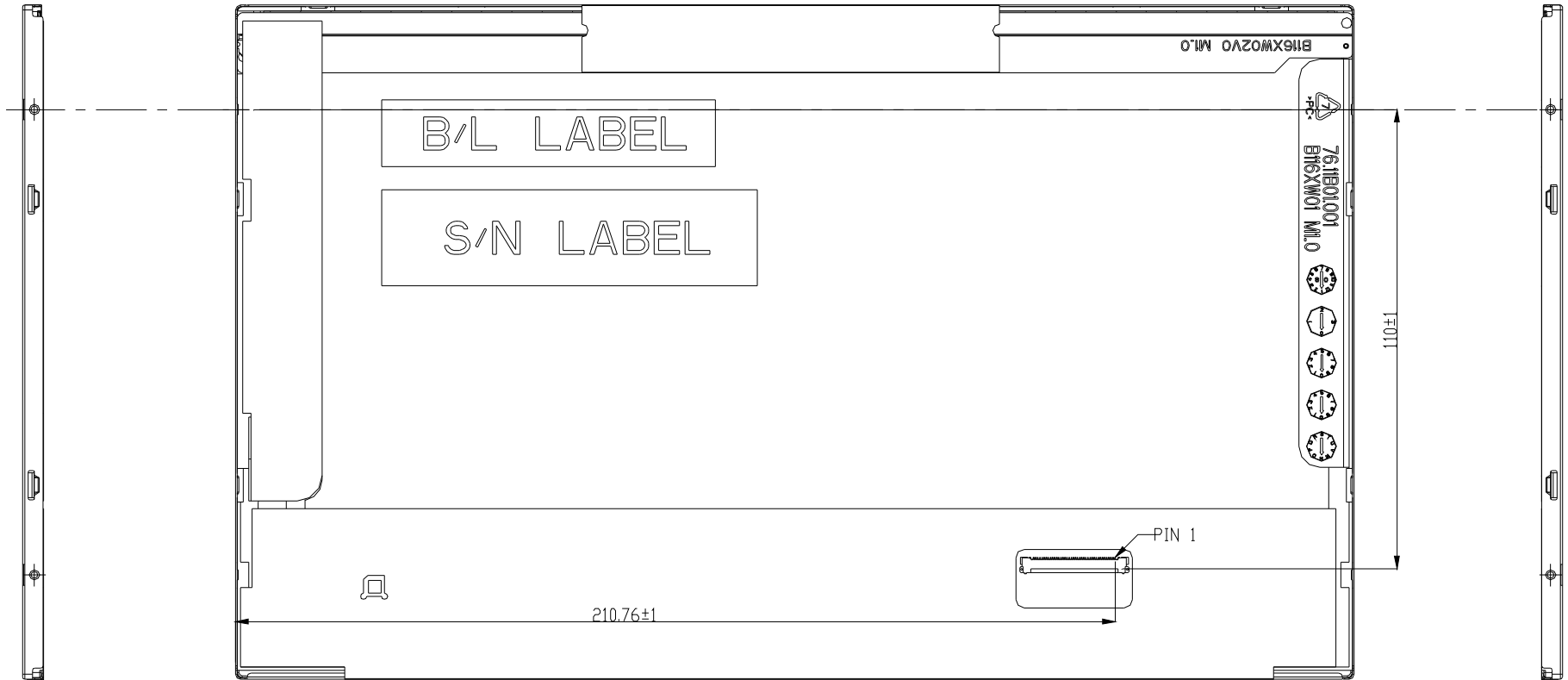

Note: Prevention IC damage, IC positions not allowed any overlap over these areas.

8.2 Screw Hole Depth and Center Position

Maximum Screw penetration from side surface is 1.9 mm

The center of screw hole center location is 2.8 ± 0.3 mm from front surface

Screw Torque: Maximum 2.5 kgf-cm

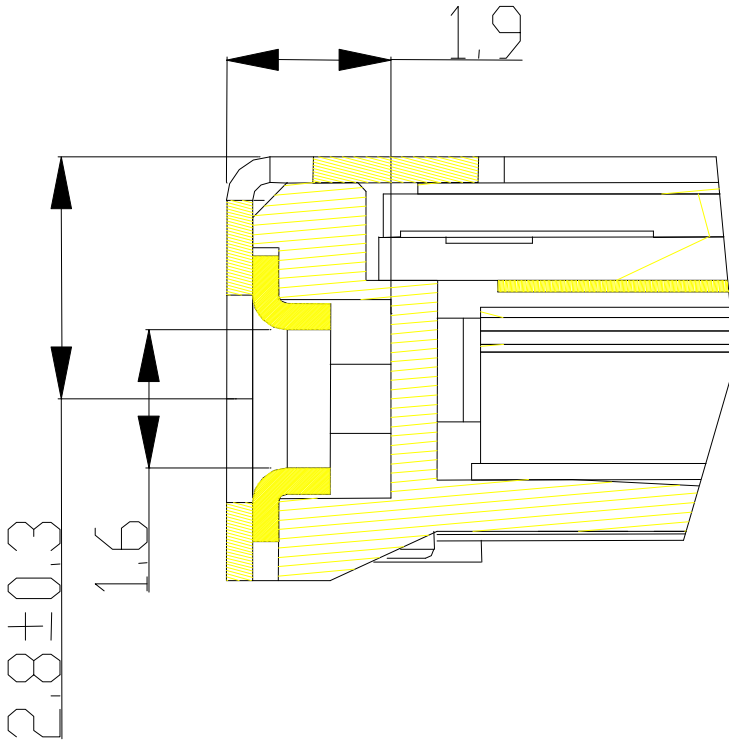



Product Specification

AU OPTRONICS CORPORATION

9. Shipping and Package

9.1 Shipping Label Format

 *XXXXXXXXXXXX-XXXXX*	Manufactured MMWW Model No: B116XW02 AU Optronics MADE IN CHINA (S01) HW: 0A FW:1	V.0 QAXXG	c  US xxxxxxx	  
---	---	----------------------------	---	---

9.2 Carton Package

The outside dimension of carton is 405(L)mm* 375(W)mm* 268(H)mm, carton and cushion weight are 2080g

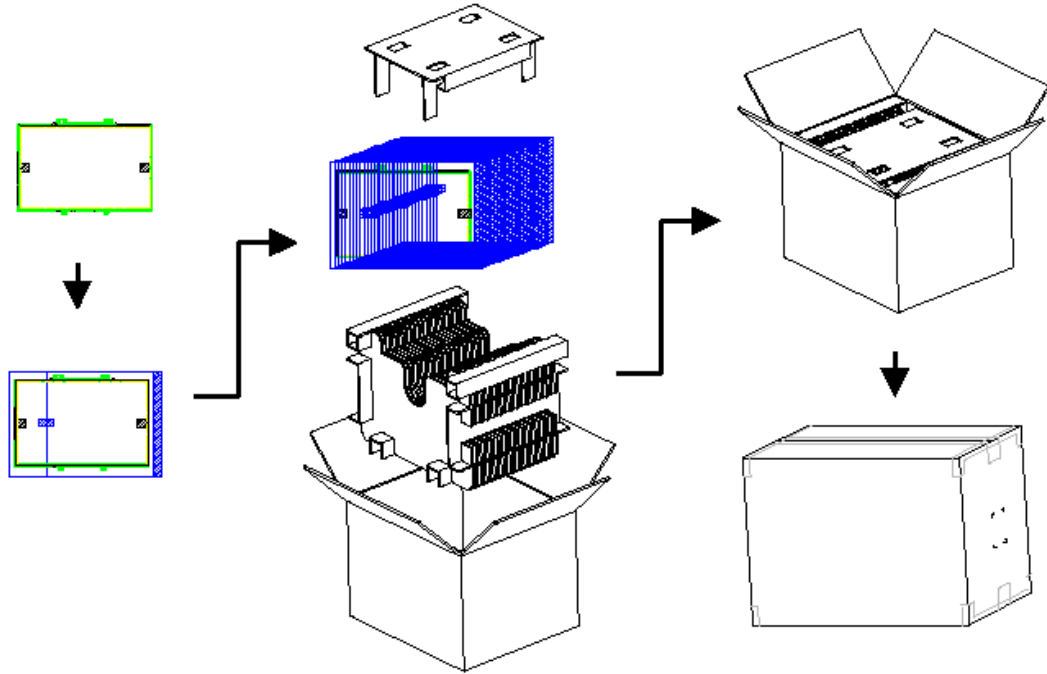

9.3 Shipping Package of Palletizing Sequence

The outside dimension of Pallet is 114(L)mm* 89(W)mm* 13.8(H)mm

By air : 6 *5 layers, one pallet put 30 boxes, total 900 pcs module.

By sea : 6 *7 layers, one pallet put 42 boxes, total 1260 pcs module.

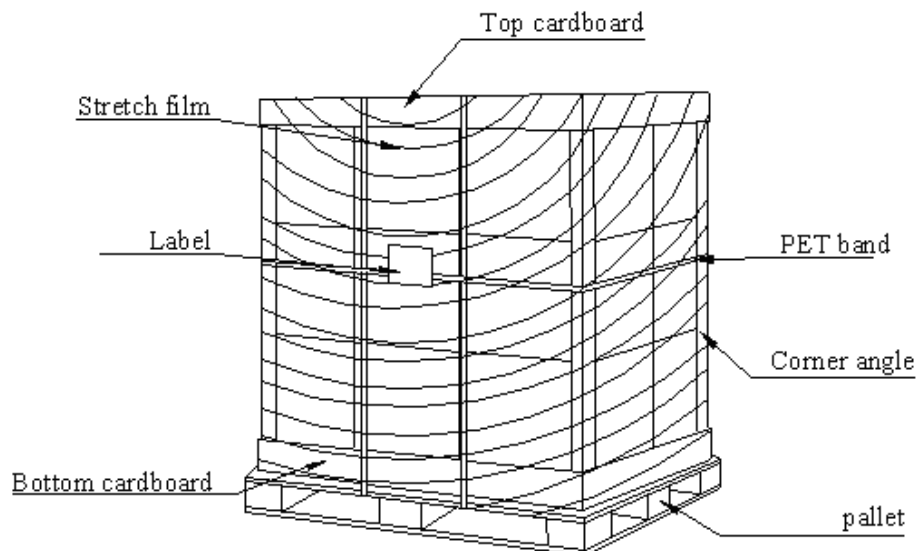



10. Appendix: EDID Description

Address	FUNCTION	Value	Value	Value	Note
HEX		HEX	BIN	DEC	
00	Header	00	00000000	0	
01		FF	11111111	255	
02		FF	11111111	255	
03		FF	11111111	255	
04		FF	11111111	255	
05		FF	11111111	255	
06		FF	11111111	255	
07		00	00000000	0	
08	EISA Manuf. Code LSB	06	00000110	6	
09	Compressed ASCII	AF	10101111	175	
0A	Product Code	5C	01011100	92	
0B	hex, LSB first	20	00100000	32	
0C	32-bit ser #	00	00000000	0	
0D		00	00000000	0	
0E		00	00000000	0	
0F		00	00000000	0	
10	Week of manufacture	01	00000001	1	
11	Year of manufacture	12	00010010	18	
12	EDID Structure Ver.	01	00000001	1	
13	EDID revision #	03	00000011	3	
14	Video input def. <small>(digital I/P, non-TMDS, CRGB)</small>	80	10000000	128	
15	Max H image size <small>(rounded to cm)</small>	1A	00011010	26	
16	Max V image size <small>(rounded to cm)</small>	0E	00001110	14	
17	Display Gamma <small>(=(gamma*100)-100)</small>	78	01111000	120	
18	Feature support <small>(no DPMS, Active OFF, RGB, tmg Blk#1)</small>	0A	00001010	10	
19	Red/green low bits (Lower 2:2:2:2 bits)	99	10011001	153	
1A	Blue/white low bits (Lower 2:2:2:2 bits)	85	10000101	133	
1B	Red x (Upper 8 bits)	95	10010101	149	
1C	Red y/ highER 8 bits	55	01010101	85	
1D	Green x	56	01010110	86	
1E	Green y	92	10010010	146	
1F	Blue x	28	00101000	40	
20	Blue y	22	00100010	34	
21	White x	50	01010000	80	
22	White y	54	01010100	84	
23	Established timing 1	00	00000000	0	
24	Established timing 2	00	00000000	0	



Product Specification

AU OPTRONICS CORPORATION

25	Established timing 3	00	00000000	0	
26	Standard timing #1	01	00000001	1	
27		01	00000001	1	
28	Standard timing #2	01	00000001	1	
29		01	00000001	1	
2A	Standard timing #3	01	00000001	1	
2B		01	00000001	1	
2C	Standard timing #4	01	00000001	1	
2D		01	00000001	1	
2E	Standard timing #5	01	00000001	1	
2F		01	00000001	1	
30	Standard timing #6	01	00000001	1	
31		01	00000001	1	
32	Standard timing #7	01	00000001	1	
33		01	00000001	1	
34	Standard timing #8	01	00000001	1	
35		01	00000001	1	
36	Pixel Clock/10000 LSB	20	00100000	32	
37	Pixel Clock/10000 USB	1C	00011100	28	
38	Horz active Lower 8bits	56	01010110	86	
39	Horz blanking Lower 8bits	80	10000000	128	
3A	HorzAct:HorzBlnk Upper 4:4 bits	50	01010000	80	
3B	Vertical Active Lower 8bits	00	00000000	0	
3C	Vertical Blanking Lower 8bits	23	00100011	35	
3D	Vert Act : Vertical Blanking (upper 4:4 bit)	30	00110000	48	
3E	HorzSync. Offset	30	00110000	48	
3F	HorzSync.Width	20	00100000	32	
40	VertSync.Offset : VertSync.Width	36	00110110	54	
41	Horz&Vert Sync Offset/Width Upper 2bits	00	00000000	0	
42	Horizontal Image Size Lower 8bits	00	00000000	0	
43	Vertical Image Size Lower 8bits	90	10010000	144	
44	Horizontal & Vertical Image Size (upper 4:4 bits)	10	00010000	16	
45	Horizontal Border <i>(zero for internal LCD)</i>	00	00000000	0	
46	Vertical Border <i>(zero for internal LCD)</i>	00	00000000	0	
47	Signal <i>(non-intr, norm, no stereo, sep sync, neg pol)</i>	18	00011000	24	
48	Detailed timing/monitor	00	00000000	0	
49	descriptor #2	00	00000000	0	
4A		00	00000000	0	
4B		0F	00001111	15	
4C		00	00000000	0	
4D		00	00000000	0	



Product Specification

AU OPTRONICS CORPORATION

4E		00	00000000	0	
4F		00	00000000	0	
50		00	00000000	0	
51		00	00000000	0	
52		00	00000000	0	
53		00	00000000	0	
54		00	00000000	0	
55		00	00000000	0	
56		00	00000000	0	
57		00	00000000	0	
58		00	00000000	0	
59		20	00100000	32	
5A	Detailed timing/monitor	00	00000000	0	
5B	descriptor #3	00	00000000	0	
5C		00	00000000	0	
5D		FE	11111110	254	
5E		00	00000000	0	
5F	Manufacture	41	01000001	65	A
60	Manufacture	55	01010101	85	U
61	Manufacture	4F	01001111	79	O
62		0A	00001010	10	
63		20	00100000	32	
64		20	00100000	32	
65		20	00100000	32	
66		20	00100000	32	
67		20	00100000	32	
68		20	00100000	32	
69		20	00100000	32	
6A		20	00100000	32	
6B		20	00100000	32	
6C	Detailed timing/monitor	00	00000000	0	
6D	descriptor #4	00	00000000	0	
6E		00	00000000	0	
6F		FE	11111110	254	
70		00	00000000	0	
71	Manufacture P/N	42	01000010	66	B
72	Manufacture P/N	31	00110001	49	1
73	Manufacture P/N	31	00110001	49	1
74	Manufacture P/N	36	00110110	54	6
75	Manufacture P/N	58	01011000	88	X
76	Manufacture P/N	57	01010111	87	W
77	Manufacture P/N	30	00110000	48	0
78	Manufacture P/N	32	00110010	50	2



Product Specification

AU OPTRONICS CORPORATION

79	Manufacture P/N	20	00100000	32	
7A	Manufacture P/N	56	01010110	86	V
7B	Manufacture P/N	30	00110000	48	0
7C		20	00100000	32	
7D		0A	00001010	10	
7E	Extension Flag	00	00000000	0	
7F	Checksum	BE	10111110	190	
SUM				5888	
SUM to HEX				1700	